

ingo-man® HS 15

paper towel dispenser
aluminium- or stainless steel housing
for all current paper towels • lockable

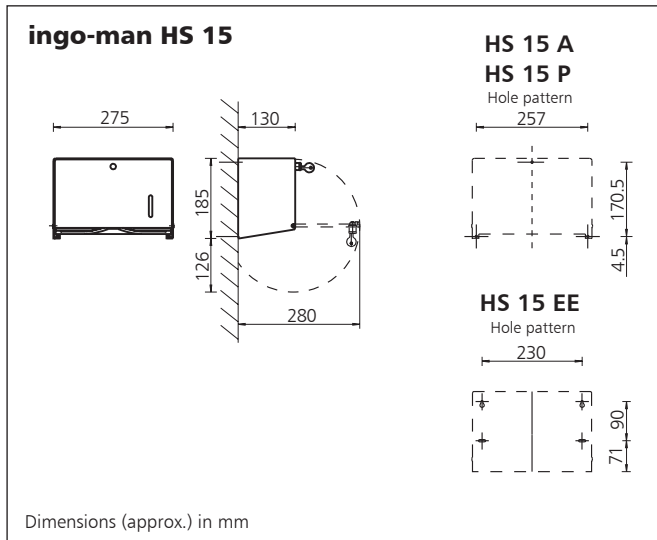

Ophardt Hygiene-Technik GmbH + Co. KG
Lindenau 27 • D-47661 Isum
Tel.: +49 2835 18-0 • Fax: +49 2835 18-77
E-Mail: info@ophardt.com • www.ophardt.com



Paper towel dispenser

- ▶ for universal application in hospitals, gastronomy, public facilities, industry etc.
- ▶ lockable housing
- ▶ visual slot for level control

Technical Data HS 15 A/HS 15 P

Housing: Aluminium, silver anodized or white powder coated (RAL 9010), with corresponding front flap,
Lock: universal snap lock, plastic (snap lock which can be actuated, if required, with or without key),
Key: Metal
Wall mounting: with three plugs and screws

Technical Data HS 15 EE

Housing: Stainless steel, ground with steel front flap
Rear plate: Stainless steel, ground
Lock: Bolting lock
Key: Metal
Wall mounting: with four plugs and screws

Description for tender

..... pcs. **ingo-man HS 15 A Art.-No. 801400**
paper towel dispenser, aluminium, silver anodized, lockable, with snap lock, the paper removal is designed comfortable, reliable and with rounded edges
Dimensions: W 275 x H 185 x D 130 mm

..... pcs. **ingo-man HS 15 P Art.-No. 801500**
paper towel dispenser, aluminium, white powder coated (RAL 9010), lockable, with snap lock, the paper removal is designed comfortable, reliable and with rounded edges
Dimensions: W 275 x H 185 x D 130 mm

..... pcs. **ingo-man HS 15 EE Art.-No. 152100**
paper towel dispenser, stainless steel, ground, lockable, the paper removal is designed comfortable, reliable and with rounded edges
Dimensions: W 275 x H 185 x D 130 mm

Product: **ingo-man®**
Manufacturer: OPHARDT HYGIENE-TECHNIK GmbH + Co. KG